



morphy richards

**3 Year
Guarantee***

*Upon registering your product at morphyrichards.co.uk

FROZO

11-IN-1

**Ice Cream & Frozen
Dessert Maker**



Model No.
431000

User Manual

Please read and keep these instructions for future use





HEALTH AND SAFETY

The use of any electrical appliance requires the following common sense safety rules.

Please read these instructions carefully before using the product.

- This appliance can be used by children aged from 8 years and above and persons with reduced physical, sensory or mental capabilities, or lack of experience and knowledge, if they have been given supervision or instruction concerning the use of the appliance in a safe way and understand the hazards involved.
- Children shall not play with the appliance.
- Cleaning and user maintenance shall not be made by children unless they are older than 8 and supervised.
- Keep the appliance and its cord out of reach of children less than 8 years.
- Avoid touching moving parts. Keep hands, hair and clothing, and utensils away from the blades during operation, to prevent





HEALTH AND SAFETY

personal injury and/or damage to the appliance.

- If the supply cable is damaged, contact Morphy Richards for advice.
- This appliance is intended for household use only. It is not suitable for use in staff kitchen areas, in shops, offices and other commercial environments.
- The appliance is not intended to be operated on an extension cable or by means of an external timer or separate remote control.



HEALTH AND SAFETY

LOCATION

- Do not use outdoors or near water.
- Always locate your appliance away from the edge of the worktop or table.
- Ensure that the appliance is used on a firm, flat, level surface.

MAINS CABLE

- The mains cable should reach from the socket to the appliance without straining the connections.
- Do not let the mains cable hang over the edge of the worktop or open space where a child could reach it.
- Do not let the cable run across a cooker or hot area which might damage the cable.
- Never leave the appliance connected to the socket outlet when not in use.

PERSONAL SAFETY

- To protect against the risk of electrical shock do not put the appliance in water or in any other liquid.
- Do not use the appliance for other than intended use.

OTHER SAFETY CONSIDERATIONS

- Do not switch on the appliance when it is upside down or laid on its side.
- Do not operate with a damaged cable or after the appliance malfunctions or has been damaged in any manner. Contact Morphy Richards for advice.
- The use of attachments or tools not recommended by Morphy Richards may cause fire, electric shock or injury.
- Do not place on or near a hot gas or electric burner.
- Do not attempt to disassemble, repair, modify, or replace any part of the product.
- Do not leave the appliance unattended while in use.



ELECTRICAL DETAILS

Check that the voltage on the rating plate of your appliance corresponds with your house electricity supply which must be A.C. (Alternating Current). Should the fuse in the mains plug require changing, replace it with a fuse of the same rating.

The power consumption in off mode is 0.28W



PRODUCT OVERVIEW

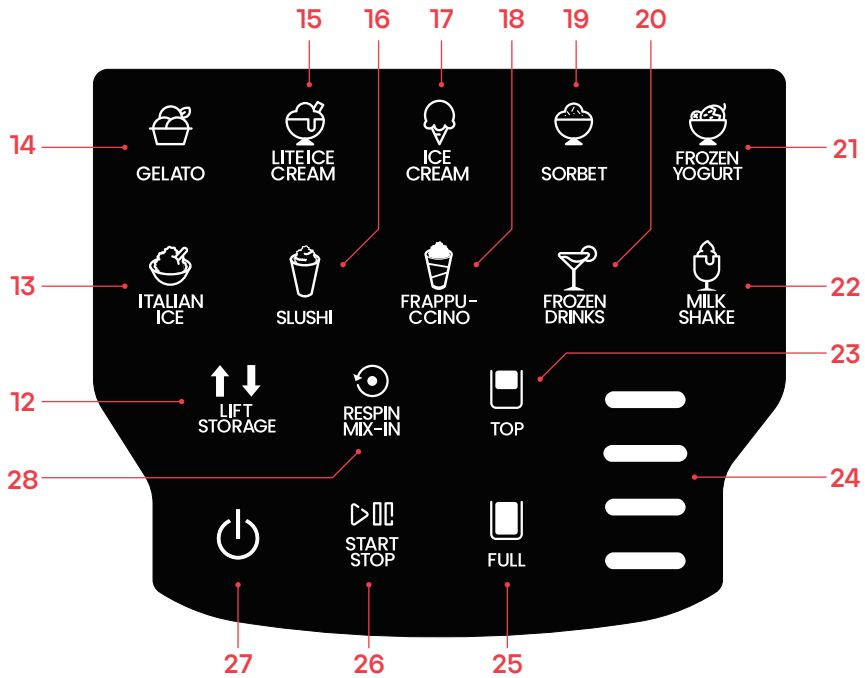
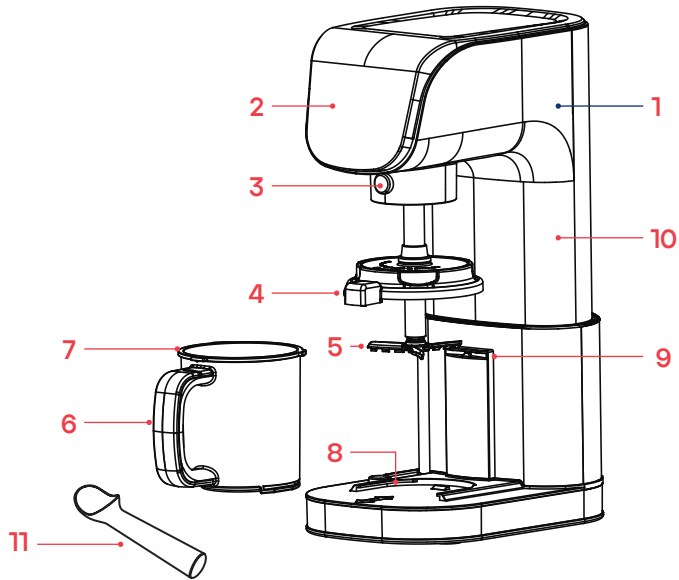



PRODUCT OVERVIEW

Features

1. Main Unit
2. Control Panel
3. Shaft Connector Button
4. Lid Assembly
5. Blending Blade Assembly
6. Dessert Container
7. Silicone Lid
8. Base Button and Locking Components
9. Lid Lock
10. Rise/Lower Shaft
11. Ice Cream Scoop

Control Panel / Display

12. Lift/Storage Button
13. Italian Ice Cream Button
14. Gelato Button
15. Lite Ice Cream Button
16. Slushi Button
17. Ice Cream Button
18. Frappuccino Button
19. Sorbet Button
20. Frozen Drinks Button
21. Frozen Yoghurt Button
22. Milk Shake Button
23. Top of Container Churn Button
24. Progress Bar
25. Full Container Churn Button
26. Start/Stop Button
27. Power On/Off Button
28. Re-Spin/ Mix-In Button



BEFORE FIRST USE

Note: When you receive your Ice Cream Maker, the Rise/Lower shaft is in its lowest position for compact packaging and safe transport.

Note: The blending blade assembly has sharp edges, handle it with care and store it out of reach of children.

1. Plug into the mains outlet and press the Lift/Storage button to raise the Rise/Lower shaft to its highest position.
2. Remove the Dessert Container and Blending Blade Assembly stored on the appliance and wash in warm soapy water. Dry thoroughly before use.
3. Prepare the ingredients for your desired recipe and add them to the Dessert Container. The Dessert Container should be stored in the freezer for approximately 24 hours.

Note: If the lid lock is on the left side of the handle, the lid cannot be locked (Figure 7). Position the lid lock on the right side of the handle. (Figure 8).

LOCATION

Ensure that the appliance is used on a firm, flat, level surface.

The Ice Cream Maker should not be placed close to heat sources such as ovens and heaters.



BLENDING SHAFT AND BLADE ASSEMBLY INSTALLATION

IMPORTANT: Always unplug from the mains outlet when installing or removing the Blending Blade Assembly.

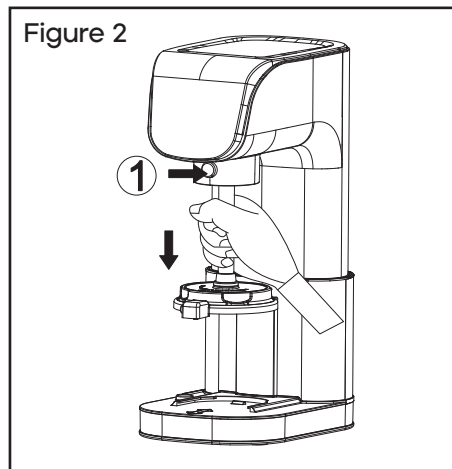
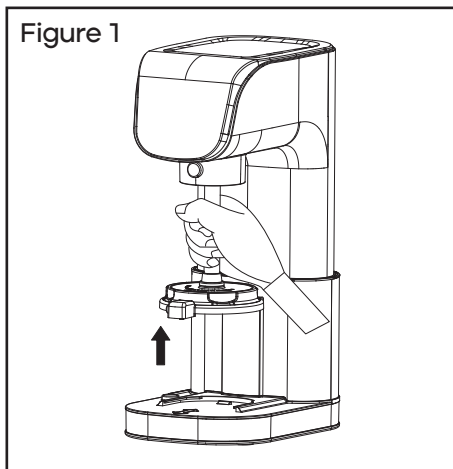

1. To install the Blending Blade Assembly, hold the blending blade shaft and align it with the mounting hole on the main unit. Push upward until you hear a 'click' (Figure 1).
2. To remove the Blending Blade Assembly, press and hold the unlock button as shown by Arrow 1 (Figure 2) then pull down on the Blending Blade Assembly to detach it.

Important: This product is NOT a blender.

Do NOT process a block of ice or ice cubes.

Do NOT make smoothies or process hard, loose ingredients such as frozen fruit. Fruit must be pre-blended to release its juice or combined with other ingredients and frozen before processing into a dessert.





CONTAINER AND LID ASSEMBLY INSTALLATION

Figure 3

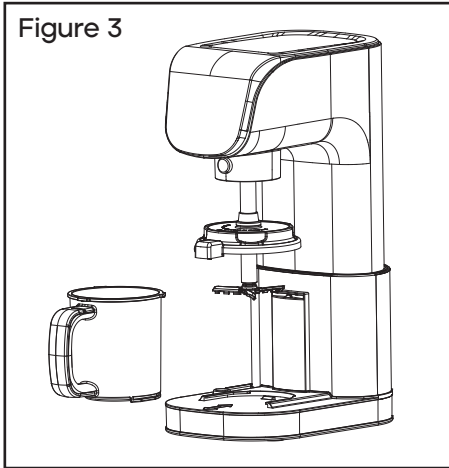
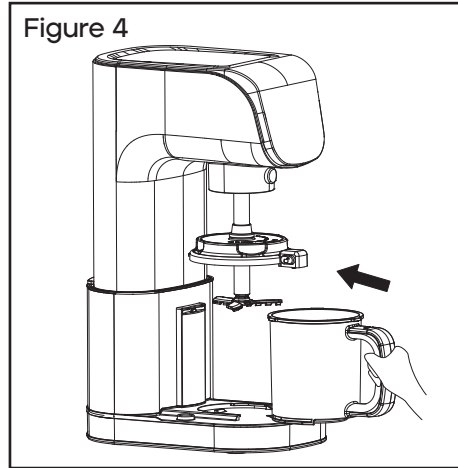
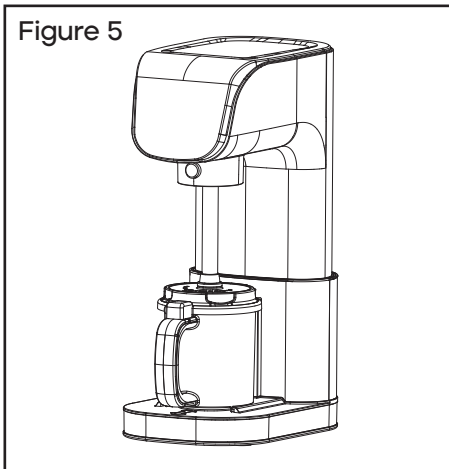

Figure 4



1. To install the Dessert Container and Lid, align the container with the slots on the base and push it in until you hear a 'click' (Figure 3).
2. Next, press the lid down to cover the container ensuring it is located correctly with the lid locking tab to the right (Figure 4).

Figure 5



3. Finally, rotate the lid to the left to secure the lid into the lid lock until you hear a click (Figure 5).
4. To remove the lid, first ensure the machine has stopped and is reset to its highest position. Press and hold the button on the lid while rotating it to the right and lifting it upwards.





CONTAINER AND LID ASSEMBLY INSTALLATION

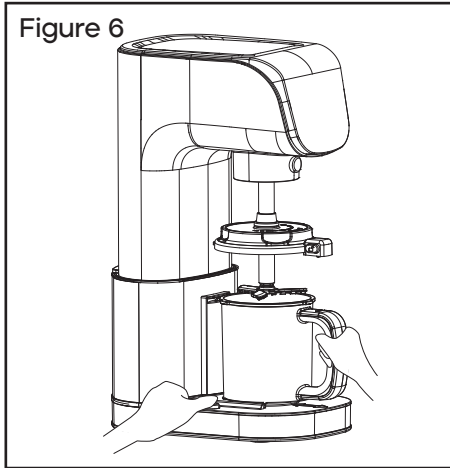

5. To remove the Dessert container, press the button on the left side of the base, and pull the container handle outwards (Figure 6).

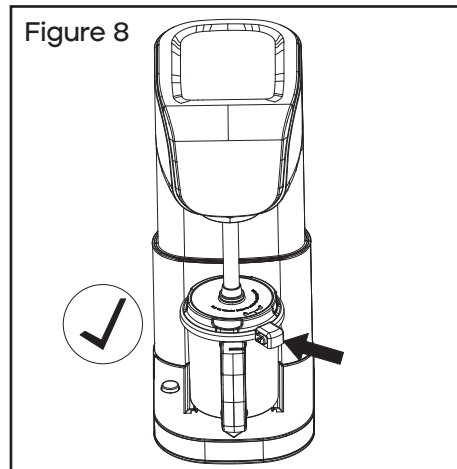
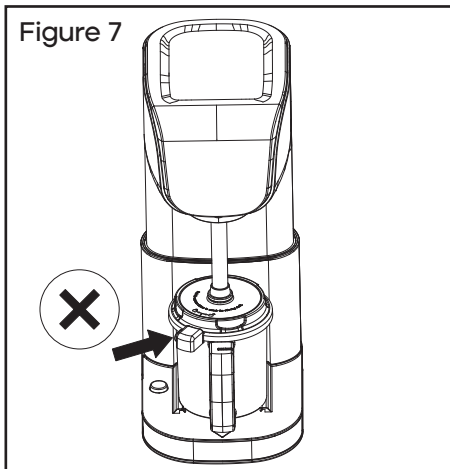

Note: If the lid lock is located to the left side of the handle, the lid cannot be locked (Figure 7). See Figure 8 for the correct position.





USING YOUR ICE CREAM MAKER

Starting and Operating Instructions

1. Press the button of the ice cream or frozen treat you wish to prepare.
2. Then choose either FULL (cup) or TOP (cup).
3. Finally, press the START/STOP button to start making your treat.

Note: After selecting a function, the default setting is FULL CUP, the indicator will flash.

Important: Do not attempt to open the lid or remove the container from the appliance until the blade has completely stopped rotating.

Important: This device is designed for processing small quantities. Do not exceed the amounts specified in the recipes.

Important: This appliance is **NOT** suitable for crushing ice.

Re-Spin/Mix-In Function

1. To achieve a smoother texture or to mix in liquids, chocolate chips or nuts etc, the Re-spin/Mix-In function can be used.
2. After adding your ingredients, ensure the lid is re-fitted securely.
3. Press the Re-spin/Mix-In button, then press the Start/Stop button to start the process.

Start/Stop

1. To pause the programme, press the Start/Stop button. The Lift/Storage button will illuminate.
2. Press the Lift/Storage button to raise Rise/Lower shaft.

Storage

To lower the Rise/Lower shaft for storage. Press the Lift/Storage button while the appliance is in standby.



USING YOUR ICE CREAM MAKER

Over Heat Protection

- To avoid damaging the appliance, do not churn more than 6 containers of ice cream/dessert continuously.
- Churning more than 6 containers of ice cream/dessert continuously may trigger the overheat protection device. The power On/Off button, Lift/Storage button and progress bar will all flash. If this happens. Switch off the appliance, unplug from the mains outlet and allow to cool for 10 minutes.

RECIPES



To download the **Frozo Ice Cream Maker Recipe Book** scan the QR code or visit the Morphy Richards website.

www.morphyrichards.co.uk

CARE AND CLEANING

Note: Before cleaning the appliance always unplug from the mains socket and wash immediately after use for easy cleaning.

1. Clean the main unit with a damp cloth only. Do not immerse in water or other liquids, rinse, or put it in the dishwasher.
2. Wash the blending shaft with blade and lid. The Dessert Containers and Silicone Lids in warm soapy water.

Note: Always dry thoroughly before next use or storing.

Note: The Dessert Containers are dishwasher safe.

Note: The blending shaft with blade and lid are not dishwasher safe.



TROUBLESHOOTING

Problem	Issue	Solution
Rapid flashing twice	System self-check	Unplug the appliance, then plug it back in and use as normal.
Rapid flashing 3 times	Excess ingredients	Add ingredients to the container's fill line only, or wait for the device to reset before trying again.
		Allow a few minutes for the appliance to re-set before switching on again.
Rapid flashing 4 times	Abnormal power consumption in standby mode	Unplug the appliance, then plug it back in and use as normal.
Rapid flashing 5 times	Circuit components may need attention	Unplug the appliance, then plug it back in and use as normal.
Slow flashing twice	Input voltage is <u>higher</u> than the normal range	Try a different appliance in the socket as it may be the socket that is at fault.
Slow flashing 3 times	Input voltage is <u>lower</u> than the normal range	Try a different appliance in the socket as it may be the socket that is at fault.
Slow flashing 4 times	Excess ingredients	Add ingredients to the container's fill line only, or wait for the device to reset before trying again.
		Allow a few minutes for the appliance to re-set before switching on again.
Slow flashing 5 times	The motor is jammed	Unplug the appliance, then plug it back in and use as normal.





TROUBLESHOOTING

Problem	Issue	Solution
All buttons are flashing	The lid lock safety switch has disconnected	Check that the dessert container and lid lock are fitted correctly. Re-install them if necessary.
The Lift/Storage button is illuminated	The motor is overloaded due to excessive ingredients	Remove ingredients from the Dessert Container and ensure it is only filled to the FILL line. Wait for the appliance to reset before trying again.
No power		Check the fuse and try a new fuse with the same rating.
		Try a different appliance in the socket as it may be the socket that is at fault.
Tripping electrics		Try using a different socket.
		Ensure there are no other appliances being used on the same set of sockets as the Ice Cream Maker.
The Power On/Off button is flashing.		Unplug the appliance and plug it back in again.



SPARE PARTS

Part Number	Description	Qty per Product	Key Number
05627	Blending Blade Assembly	1	5
05628	Dessert tub	3 (sold individually)	6
05629	Silicone lid	3 (sold individually)	7
05630	Ice cream scoop	1	11





CONTACT US

If you are having a problem with your appliance, please contact our Helpline, as we are more likely to be able to help than the store you purchased the item from. Please have the product name, model number and serial number to hand when you contact us to help us deal with your enquiry quicker.

email: hello@morphyrichards.co.uk

www.morphyrichards.co.uk

PRODUCT RECYCLING



For electrical products sold within the European Community, at the end of the electrical products useful life, it should not be disposed of with household waste.

Please recycle where facilities exist.

Check with your Local Authority or retailer for recycling advice in your country.



REGISTERING YOUR 3 YEAR GUARANTEE

Your standard 2 year guarantee is extended for an additional 1 year when you register the product within 28 days of purchase with Morphy Richards. If you do not register the product with Morphy Richards within 28 days, your product is guaranteed for 2 years.



To validate your 3 year guarantee, scan the QR code or register online at www.morphyrichards.co.uk

N.B. Each qualifying product needs to be registered with Morphy Richards individually. Please note that the 2 year guarantee is only available in the UK. Please refer to the 2 year guarantee for more information.

YOUR 2 YEAR GUARANTEE

It is important to retain the retailer's receipt as proof of purchase. Staple your receipt to the back cover for future reference.

Please quote the following information if the product develops a fault. These numbers can be found on the base of the product.

Model no.

Serial no.

All Morphy Richards products are individually tested before leaving the factory. In the unlikely event of any appliance proving to be faulty within 28 days of purchase, it should be returned to the place of purchase for it to be replaced. If the fault develops after 28 days and within 24 months of original purchase, you should contact the Helpline quoting Model number and Serial number on the product, or write to Morphy Richards at the address shown. You may be asked to return a copy of proof of purchase.

Subject to the exclusions set out on the next page (see Exclusions), the faulty appliance will then be repaired or replaced as appropriate and dispatched usually within 7 working days of receipt.

If, for any reason, this item is replaced or repaired during the 2 year





REGISTERING YOUR 3 YEAR GUARANTEE

guarantee period, the guarantee on the new item will be calculated from the original purchase date. Therefore it is vital to retain your original till receipt or invoice to indicate the date of initial purchase.

To qualify for the 2 year guarantee, the appliance must have been used according to the instructions supplied.

The appliance is intended for domestic use only. Misuse or use for commercial or any other purpose will render the guarantee invalid.

Exclusions

Morphy Richards shall not be liable to replace or repair the goods under the terms of the guarantee where:

1. The fault has been caused or is attributable to accidental use, misuse, negligent use or used contrary to the manufacturer's recommendations or where the fault has been caused by power surges or damage caused in transit.
2. The appliance has been used on a voltage supply other than that stamped on the products.
3. Repairs have been attempted by persons other than our service staff (or authorised dealer).
4. The appliance has been used for hire purposes or non domestic use.
5. The appliance is second hand or refurbished.
6. Morphy Richards reserves the right not to carry out any type of servicing under the guarantee at its discretion.

This guarantee does not confer any rights other than those expressly set out above and does not cover any claims for consequential loss or damage. This guarantee is offered as an additional benefit and does not affect your statutory rights as a consumer. Morphy Richards products are intended for household use only. See usage limitations within the location safety instructions.

Disclaimer

Morphy Richards has a policy of continuous improvement in product quality and design. The company, therefore reserves the right to change the specification of its models at any time.



FP431000MUK Rev1

morphy richards



@morphyrichardsuk #loveyourmorphy

morphyrichards.co.uk

Morphy Richards
9 Cabot Lane, Poole, Dorset, BH17 7BY, UK

